

VALVOLE VARIE FURTHER VALVES

		Descrizione - Description	Type	Page
	NEW!	VALVOLA DI FINE CORSA - NORMALMENTE CHIUSO <i>END-STROKE VALVE - NORMALLY CLOSED</i>	FCS-C	282
	NEW!	VALVOLA DI FINE CORSA - NORMALMENTE CHIUSO <i>END-STROKE VALVE - NORMALLY CLOSED</i>	FC-C	282
	NEW!	VALVOLA DI FINE CORSA - NORMALMENTE APERTO <i>END-STROKE VALVE - NORMALLY OPEN</i>	FC-A	283
	NEW!	VALVOLA DI FINE CORSA CON CAMMA - NORMALMENTE CHIUSO <i>MECHANICAL DRIVE END-STROKE VALVE - NORMALLY CLOSED</i>	V-FCC..NC	283
		VALVOLA DI FINE CORSA - NORMALMENTE CHIUSO <i>END-STROKE VALVE - NORMALLY CLOSED</i>	FCV...NC	284
		VALVOLA DI FINE CORSA - NORMALMENTE APERTO <i>END-STROKE VALVE - NORMALLY OPEN</i>	FCV...NA	284
		VALVOLA DI FINE CORSA - NORMALMENTE APERTO <i>END-STROKE VALVE - NORMALLY OPEN</i>	FCR-1T NA	285
		VALVOLA DI FINE CORSA - NORMALMENTE CHIUSO <i>END-STROKE VALVE - NORMALLY CLOSED</i>	FCR-2T NC	285
		VALVOLA DI RIBALTAMENTO ARATRO <i>PLOUGH OVERTURNING VALVE</i>	VRAP DE	286
	NEW!	VALVOLA DI RIBALTAMENTO ARATRO <i>PLOUGH OVERTURNING VALVE</i>	VRAP DE + VMP	286
	NEW!	VALVOLA SBLOCCAFRENO PER MOTORI "MP-MR" <i>BRAKE UNCLAMPING VALVE FOR "MP-RR" MOTORS</i>	VSBF-MP/R	287
	NEW!	VALVOLA SBLOCCAFRENO PER MOTORI "MS" <i>BRAKE UNCLAMPING VALVE FOR "MS" MOTORS</i>	VSBF-MS	287
	NEW!	VALVOLA RIGENERATRICE DI CIRCUITO <i>REGENERATIVE VALVE</i>	VRSP	288

FCS-C

NEW!

VALVOLA DI FINE CORSA - NORMALMENTE CHIUSO
END-STROKE VALVE - NORMALLY CLOSED

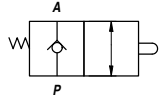
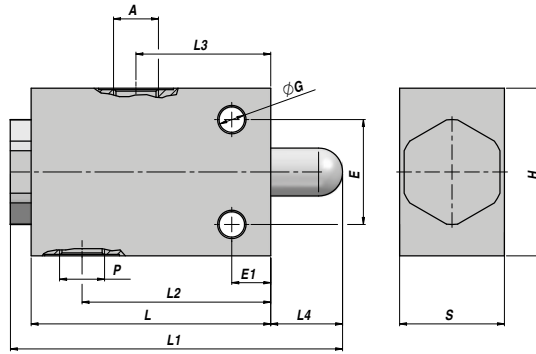
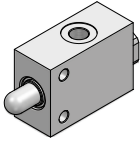

Codice Code	A - P BSP	Q MAX l/min	P MAX bar	Tipo Type	L	L1	L2	L3	L4	ØG	E	E1	H	S	kg
VSG104.020000	3/8"	30	300	FCS-C 020	65	83	43	30	10	8.5	35	13.5	60	30	0,79
VSG104.030000	1/2"	60	300	FCS-C 030	80	103	51	37	13	10.5	40	13.5	75	35	1,28

MATERIALE CORPO : ACCIAIO
BODY MATERIAL : STEEL

MONTAGGIO IN LINEA
LINE MOUNTING

FC-C

NEW!

VALVOLA DI FINE CORSA - DOPPIO RITEGNO - NORMALMENTE CHIUSO
END-STROKE VALVE - DOUBLE LOCK - NORMALLY CLOSED

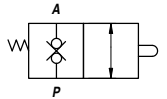
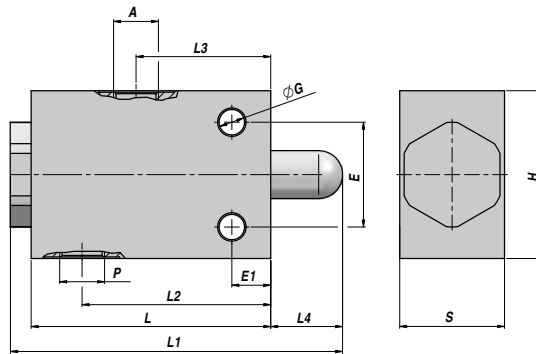
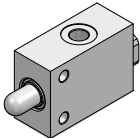

Codice Code	A - P BSP	Q MAX l/min	P MAX bar	Tipo Type	L	L1	L2	L3	L4	ØG	E	E1	H	S	kg
VSG105.020000	3/8"	30	300	FC-C 020	65	83	43	30	10	8.5	35	13.5	60	30	0,79
VSG105.030000	1/2"	60	300	FC-C 030	80	103	51	37	13	10.5	40	13.5	75	35	1,30

MATERIALE CORPO : ACCIAIO
BODY MATERIAL : STEEL

MONTAGGIO IN LINEA
LINE MOUNTING

VALVOLA DI FINE CORSA - NORMALMENTE APERTO
END-STROKE VALVE - NORMALLY OPEN

NEW!

FC-A

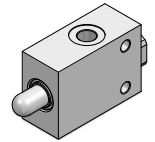
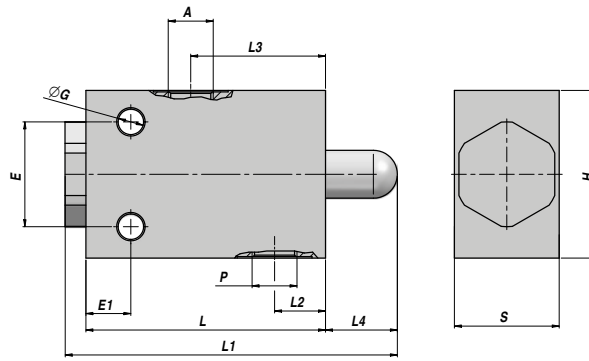
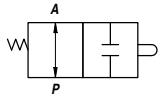

Codice Code	A - P BSP	Q MAX l/min	P MAX bar	Tipo Type	L	L1	L2	L3	L4	ØG	E	E1	H	S	kg
VSG106.020000	3/8"	30	300	FC-A 020	65	81.5	17	28	12	8.5	40	15	60	30	0.80
VSG106.030000	1/2"	60	300	FC-A 030	65	81.5	17	28	12	8.5	40	15	60	30	0.80

MATERIALE CORPO : ACCIAIO
 BODY MATERIAL : STEEL

MONTAGGIO IN LINEA
 LINE MOUNTING

VALVOLA DI FINE CORSA CON CAMMA - NORMALMENTE CHIUSO
MECHANICAL DRIVE END-STROKE VALVE - NORMALLY CLOSED

NEW!

V-FCC..NC

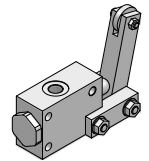
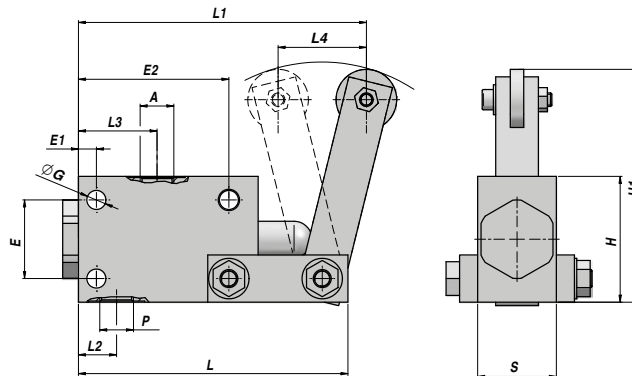
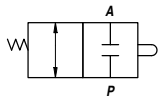

Codice Code	A - P BSP	Q MAX l/min	P MAX bar	Tipo Type	L	L1	L2	L3	L4	ØG	E	E1	E2	H1	H	S	kg
V7090.0815	1/2"	70	350	V-FCC 1/2"-NC	107	124.5	24.5	45	48	7	35	7	55	112.5	50	35	1,28

MATERIALE CORPO : ACCIAIO
 BODY MATERIAL : STEEL

MONTAGGIO IN LINEA
 LINE MOUNTING

FCV ... NC

**VALVOLA DI FINE CORSA - NORMALMENTE CHIUSO
END-STROKE VALVE - NORMALLY CLOSED**

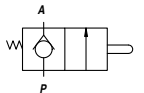
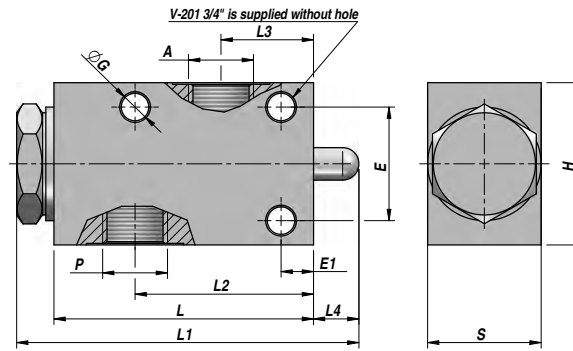

Codice Code	A - P BSP	Q MAX l/min	P MAX bar	Tipo Type	L	L1	L2	L3	L4	ØG	E	E1	H	S	kg
V7015.0600	3/8"	50	350	FC V-101 NC	80	105	55	30.0	14	8.5	35	10	50	35	0,96
V7015.0800	1/2"	70	350	FC V-121 NC	80	105	55	28.5	14	8.5	35	10	50	35	0,93
V7015.1200	3/4"	100	350	FC V-201 NC	88	115	61	23.0	14	8.5	50	20	70	45	0,86

MATERIALE CORPO : ACCIAIO
BODY MATERIAL : STEEL

MONTAGGIO IN LINEA
LINE MOUNTING

FCV ... NA

**VALVOLA DI FINE CORSA - NORMALMENTE APERTO
END-STROKE VALVE - NORMALLY OPEN**

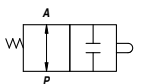
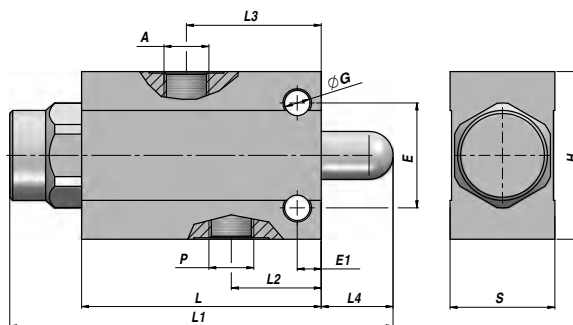
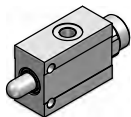

Codice Code	A - P BSP	Q MAX l/min	P MAX bar	Tipo Type	L	L1	L2	L3	L4	ØG	E	E1	H	S	kg
V7090.0817	3/8"	40	350	FC V-101 NA	80	129	30	45	24	8.5	35	8	56	35	1,24
V7090.0818	1/2"	60	350	FC V-121 NA	80	129	30	45	24	8.5	35	8	62	35	1,38

MATERIALE CORPO : ACCIAIO
BODY MATERIAL : STEEL

MONTAGGIO IN LINEA
LINE MOUNTING

VALVOLA DI FINE CORSA - NORMALMENTE APERTO
END-STROKE VALVE - NORMALLY OPEN

FCR-1T NA

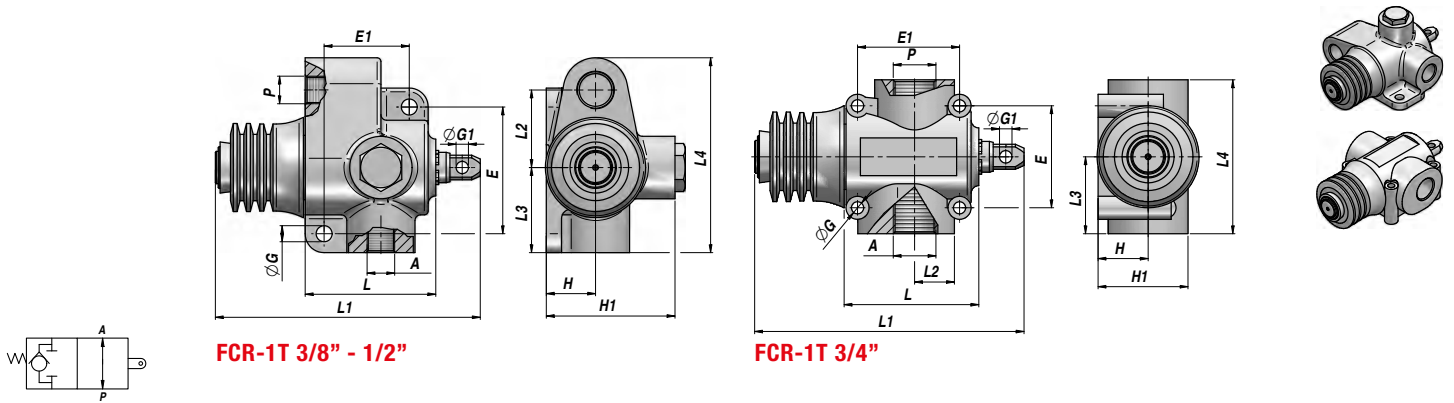

Codice Code	A - P BSP	Q MAX l/min	P MAX bar	Tipo Type	L	L1	L2	L3	L4	ØG	ØG1	E	E1	H	H1	kg
V7090.0824	3/8"	60	350	FCR-1T 60-NA 38	69	130	41.0	45	103	8.5	6.5	66	45	26.0	68	1,63
V7090.0826	1/2"	80	350	FCR-1T 80-NA 12	69	130	41.0	45	103	8.5	6.5	66	45	26.0	68	1,62
V7090.1200	3/4"	120	350	FCR-1T120-NA 34	88	173	23.5	46	92	8.5	13.0	50	56	27.5	50	2,11

MATERIALE CORPO : GHISA
 BODY MATERIAL : CAST IRON

MONTAGGIO IN LINEA
 LINE MOUNTING

VALVOLA DI FINE CORSA - NORMALMENTE CHIUSO
END-STROKE VALVE - NORMALLY CLOSED

FCR-2T NC

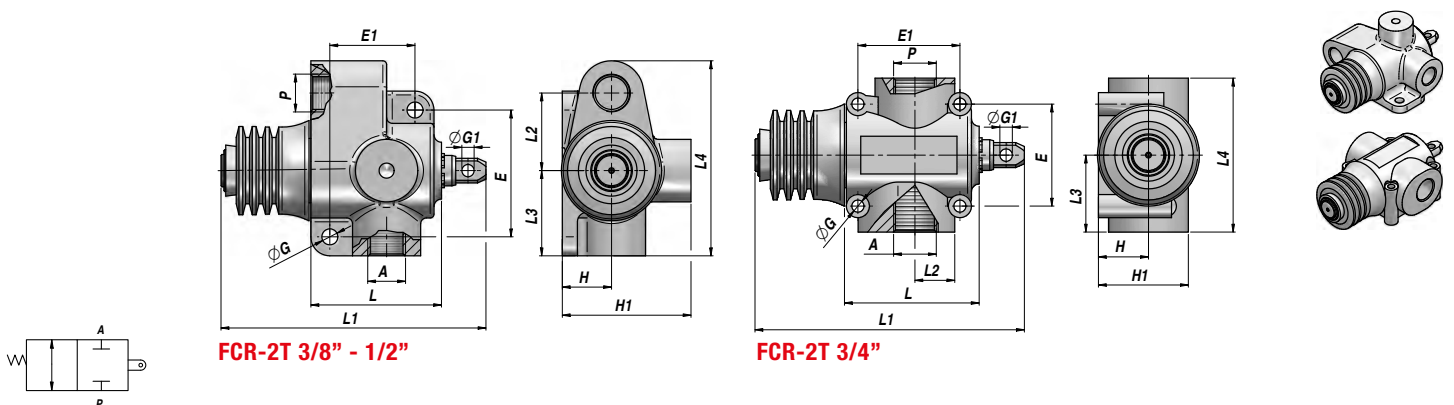

Codice Code	A - P BSP	Q MAX l/min	P MAX bar	Tipo Type	L	L1	L2	L3	L4	ØG	ØG1	E	E1	H	H1	kg
V7090.0820	3/8"	60	350	FCR-2T 60-NC 38	69	130	41.0	45	103	8.5	6.5	66	45	26.0	68	1,65
V7090.0822	1/2"	80	350	FCR-2T 80-NC 12	69	130	41.0	45	103	8.5	6.5	66	45	26.0	68	1,65
V7090.0823	3/4"	120	350	FCR-2T120-NC 34	88	179	23.5	46	92	8.5	13.0	50	56	27.5	50	2,20

MATERIALE CORPO : GHISA
 BODY MATERIAL : CAST IRON

MONTAGGIO IN LINEA
 LINE MOUNTING

VRAP DE

**DOPPIO EFFETTO
DOUBLE ACTING**

**VALVOLA DI RIBALTAMENTO ARATRO
PLOUGH OVERTURNING VALVE**

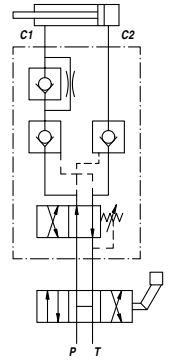
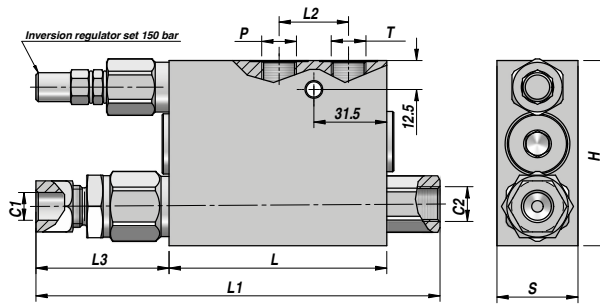
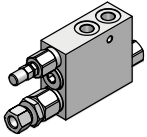

Codice Code	P - T BSP	C2 BSP	C1	Inversion Pressure MAX bar	P MAX bar	Tipo Type	L	L1	L2	L3	H	S	kg
V1867.0282	3/8"	3/8"	Ø12	250	400	VRAP 40/ 50 DE	94	176	30	58	80	35	2,13
V1867.0600	3/8"	3/8"	Ø12	250	400	VRAP 60/ 80 DE	94	176	30	58	80	35	2,14
V1867.0601	3/8"	3/8"	Ø12	250	400	VRAP 80/100 DE	94	176	30	58	80	35	2,14
V1867.0302	3/8"	3/8"	Ø12	250	400	VRAP 100/110 DE	94	176	30	58	80	35	2,14
V1867.0320	3/8"	3/8"	Ø12	250	400	VRAP 110/130 DE	94	176	30	58	80	35	2,13

MATERIALE CORPO : ACCIAIO
BODY MATERIAL : STEEL

MONTAGGIO SU CILINDRO
CYLINDER MOUNTING

VRAP DE-VMP

NEW!

**DOPPIO EFFETTO
DOUBLE ACTING**

**VALVOLA DI RIBALTAMENTO ARATRO
PLOUGH OVERTURNING VALVE**

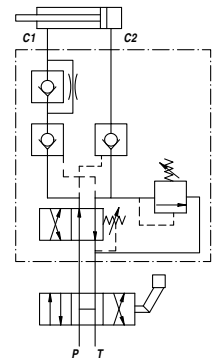
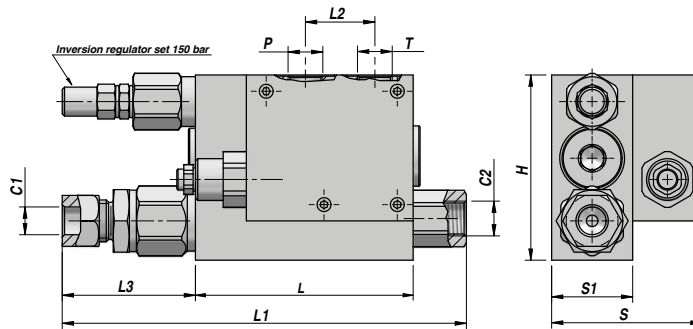
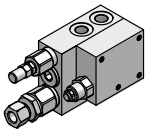

Codice Code	P - T BSP	C2 BSP	C1	Inversion Pressure MAX bar	P MAX bar	Tipo Type	L	L1	L2	L3	H	S	kg
V1867.0350	3/8"	3/8"	Ø12	250	400	VRAP 60/ 80 DE+VMP	94	176	30	58	80	65	3,20
V1867.0360	3/8"	3/8"	Ø12	250	400	VRAP 80/100 DE+VMP	94	176	30	58	80	65	3,19
V1867.0376	3/8"	3/8"	Ø12	250	400	VRAP 100/110 DE+VMP	94	176	30	58	80	65	3,19
V1867.0380	3/8"	3/8"	Ø12	250	400	VRAP 110/130 DE+VMP	94	176	30	58	80	65	3,16

MATERIALE CORPO : ACCIAIO
BODY MATERIAL : STEEL

MONTAGGIO SU CILINDRO
CYLINDER MOUNTING

VALVOLA SBLOCCAFRENO PER MOTORI "MPP-MPR-MCP-MCR"
BRAKE UNCLAMPING VALVE FOR "MPP-MPR-MCP-MCR" MOTORS

NEW!

VSBF (MP-MR)

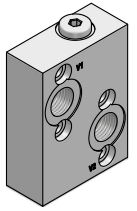
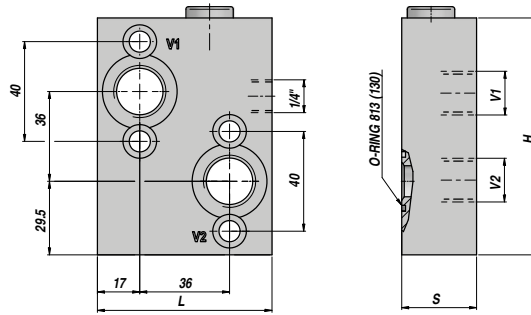
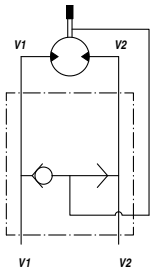

Codice Code	V1 - V2 BSP	Q MAX l/min	P MAX bar	Tipo Type	L	H	S	kg
V6090.0333	1/2"	60	300	VSBF 1/2" MP/R	70	95	30	1,31

MATERIALE CORPO : ACCIAIO
 BODY MATERIAL : STEEL

FLANGIABILE
 FACE MOUNTING

VALVOLA SBLOCCAFRENO PER MOTORI "MPS-MCS"
BRAKE UNCLAMPING VALVE FOR "MPS-MCS" MOTORS

NEW!

VSBF (MS)

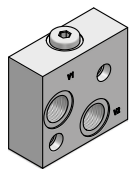
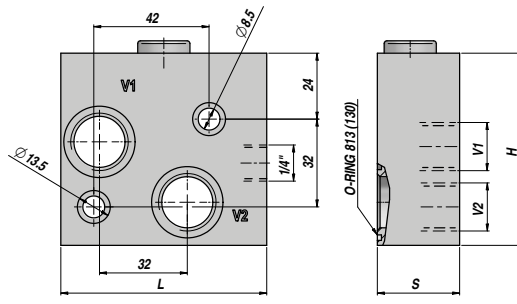
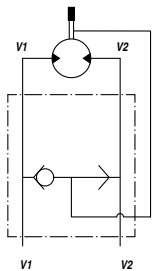

Codice Code	V1 - V2 BSP	Q MAX l/min	P MAX bar	Tipo Type	L	H	S	kg
V6090.0334	1/2"	40	300	VSBF 1/2" MS	75	70	30	1,31

MATERIALE CORPO : ACCIAIO
 BODY MATERIAL : STEEL

FLANGIABILE
 FACE MOUNTING

VRSP

NEW!

**VALVOLA RIGENERATRICE DI CIRCUITO
REGENERATIVE VALVE**

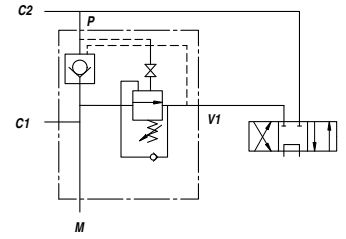
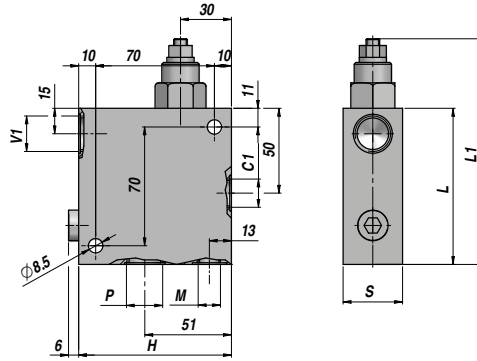
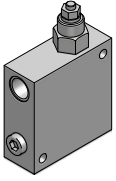

Codice Code	V1-P-C1 BSP	M BSP	Q MAX l/m	P MAX bar	Tipo Type	L	L1 max	H	S	kg
V4790.1220	1/2"	1/4"	60	350	VRSP 1/2"	92	142	90	35	2,03
V4790.1230	3/4"	1/4"	95	350	VRSP 3/4"	120	177	105	40	3,50

MOLLA - SPRING :B= 60:350 bar (Standard)

MATERIALE CORPO : ACCIAIO
BODY MATERIAL : STEEL

MONTAGGIO IN LINEA
LINE MOUNTING